

Material List: ALL 316 STAINLESS STEEL

1-15/16" x 3/16"	316 S.S. Sch 40-P	Top Cap
1-15/16" x 1/4"	316 S.S. Sch 80-P	Support Post (End)
1-15/16" x 3/16"	316 S.S. Sch 40-P	Support Post (Mid)
3/16" Dia.	316 S.S. 1 x 19	Cable (Recommended)
3/16" Dia.	316 S.S. 7 x 7	Cable (Option)
1-5/16 x 1/8"	316 S.S. Sch 40-P	Bottom Rail
6" Dia. x 3/8"	316 S.S. W.J. Cut	Base Plate (Option)

All rights reserved and are the property of Mullet's Aluminum Products, Inc. No part of the materials may be copied, photocopied, reproduced, translated or reduced to any electronic medium or machine-readable form, in whole or in part, without prior written consent of Mullet's Products, Inc. All materials are protected by United States Copyright Law.

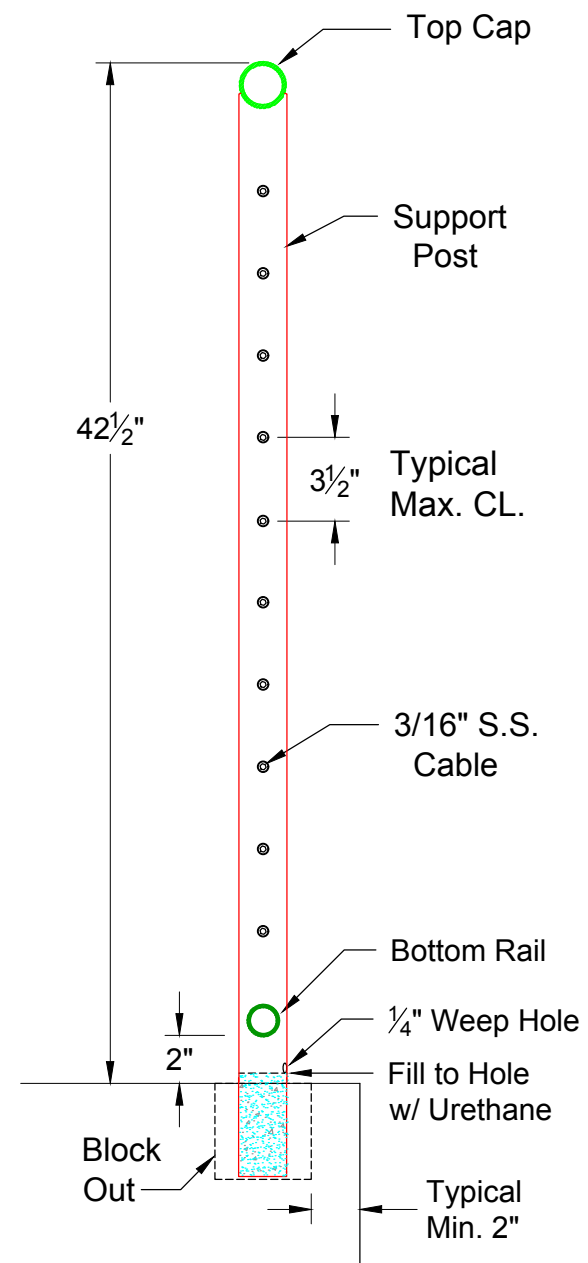

ENLARGED SECTION 1 1/2" = 1' - 0"

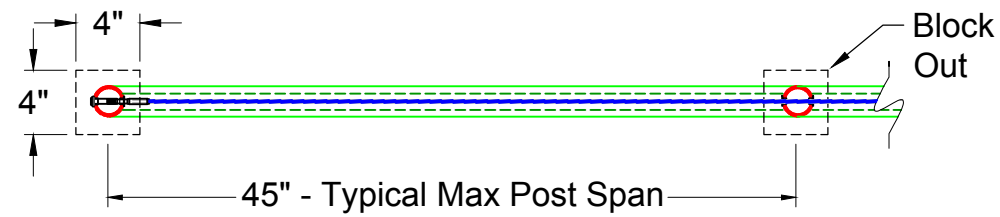

PLAN VIEW 1" = 1' - 0"

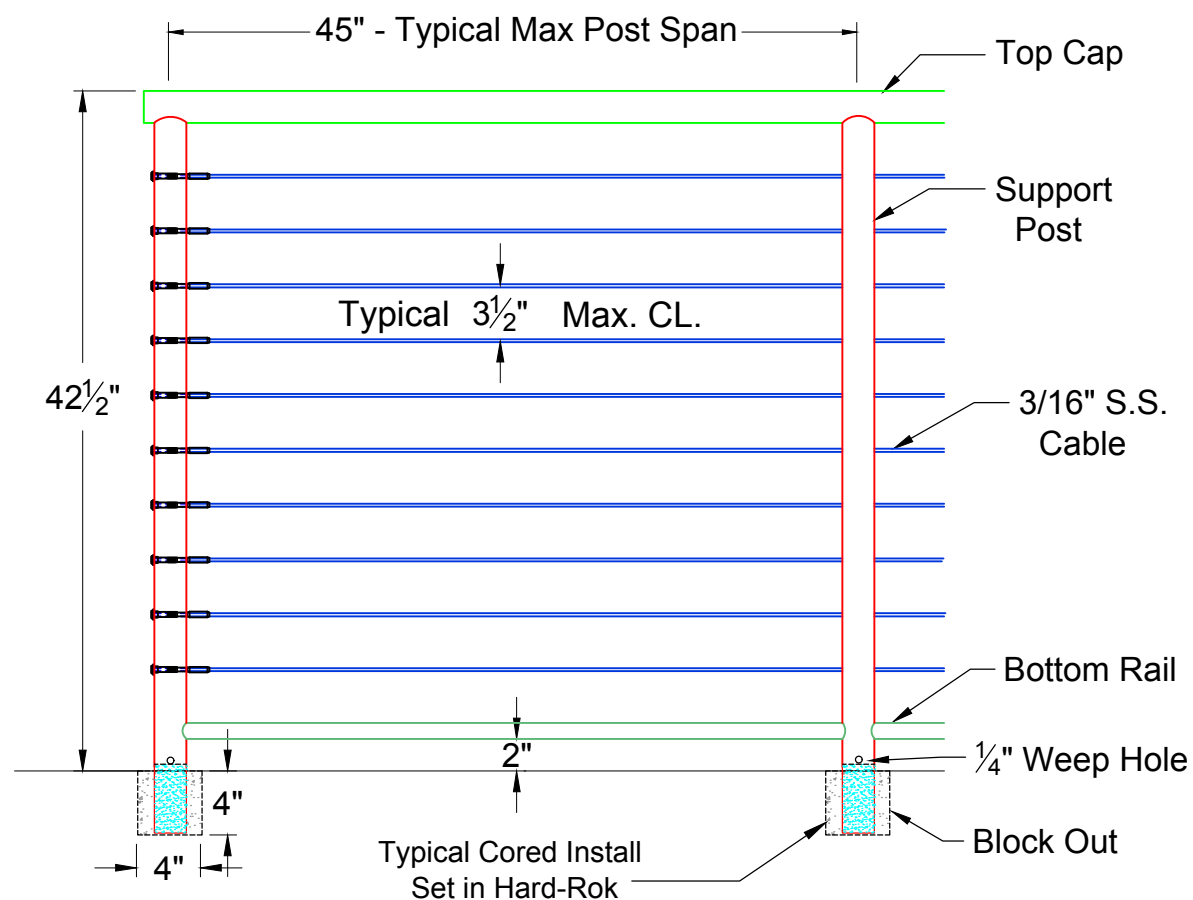

ELEVATION 1" = 1' - 0"

Dimensions and Components may vary based on Site Specific Engineering

Date:	May. 23, 19	Customer:	MULLET'S ALUMINUM
Drawn By:	Nick, L.	Project Name:	RAILINGS
Scale:	AS NOTED	Drawing Description:	CBRS - 200 S.S. Typ. Core Mount
			Page : (1)

MULLET'S ALUMINUM PRODUCTS INC.
 WELDING FABRICATION DEPT.
 6345 McIntosh Road Office # (941) 371 - 3502
 Sarasota, FL 34238 Fax # (941) 378 - 5676

Material List: ALL 316 STAINLESS STEEL

1-15/16" x 3/16"	316 S.S. Sch 40-P	Top Cap
1-15/16" x 1/4"	316 S.S. Sch 80-P	Support Post (End)
1-15/16" x 3/16"	316 S.S. Sch 40-P	Support Post (Mid)
3/16" Dia.	316 S.S. 1 x 19	Cable (Recommended)
3/16" Dia.	316 S.S. 7 x 7	Cable (Option)
1-5/16" x 1/8"	316 S.S. Sch 40-P	Bottom Rail
6" Dia. x 3/8"	316 S.S. W.J. Cut	Base Plate (Option)

All rights reserved and are the property of Mullet's Aluminum Products, Inc. No part of the materials may be copied, photocopied, reproduced, translated or reduced to any electronic medium or machine-readable form, in whole or in part, without prior written consent of Mullet's Products, Inc. All materials are protected by United States Copyright Law.

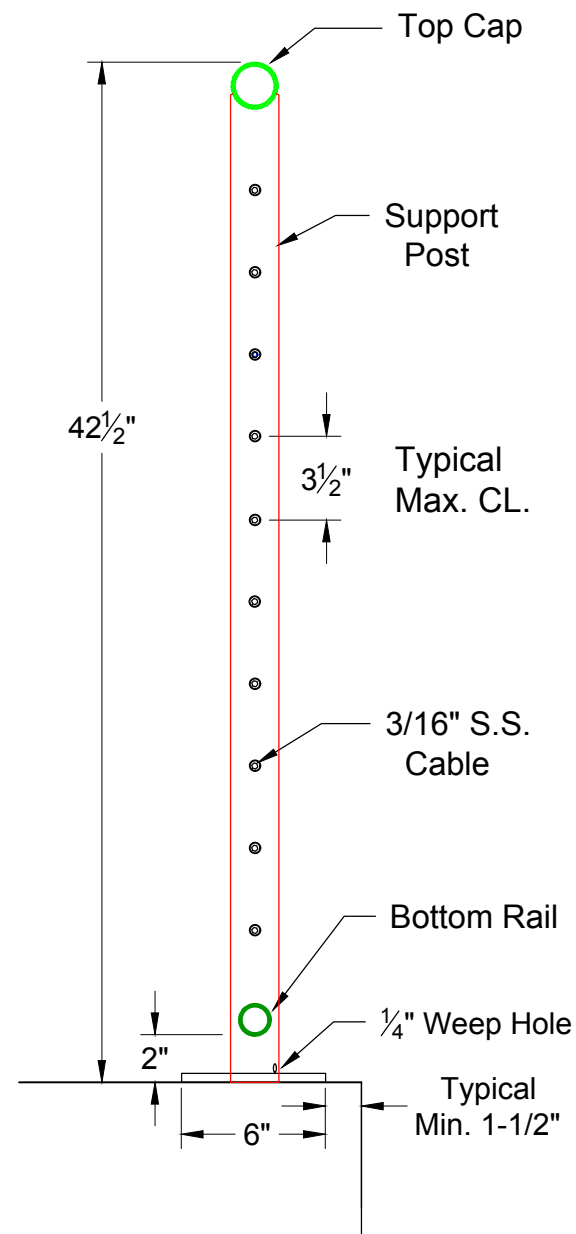

ENLARGED SECTION 1/2" = 1' - 0"

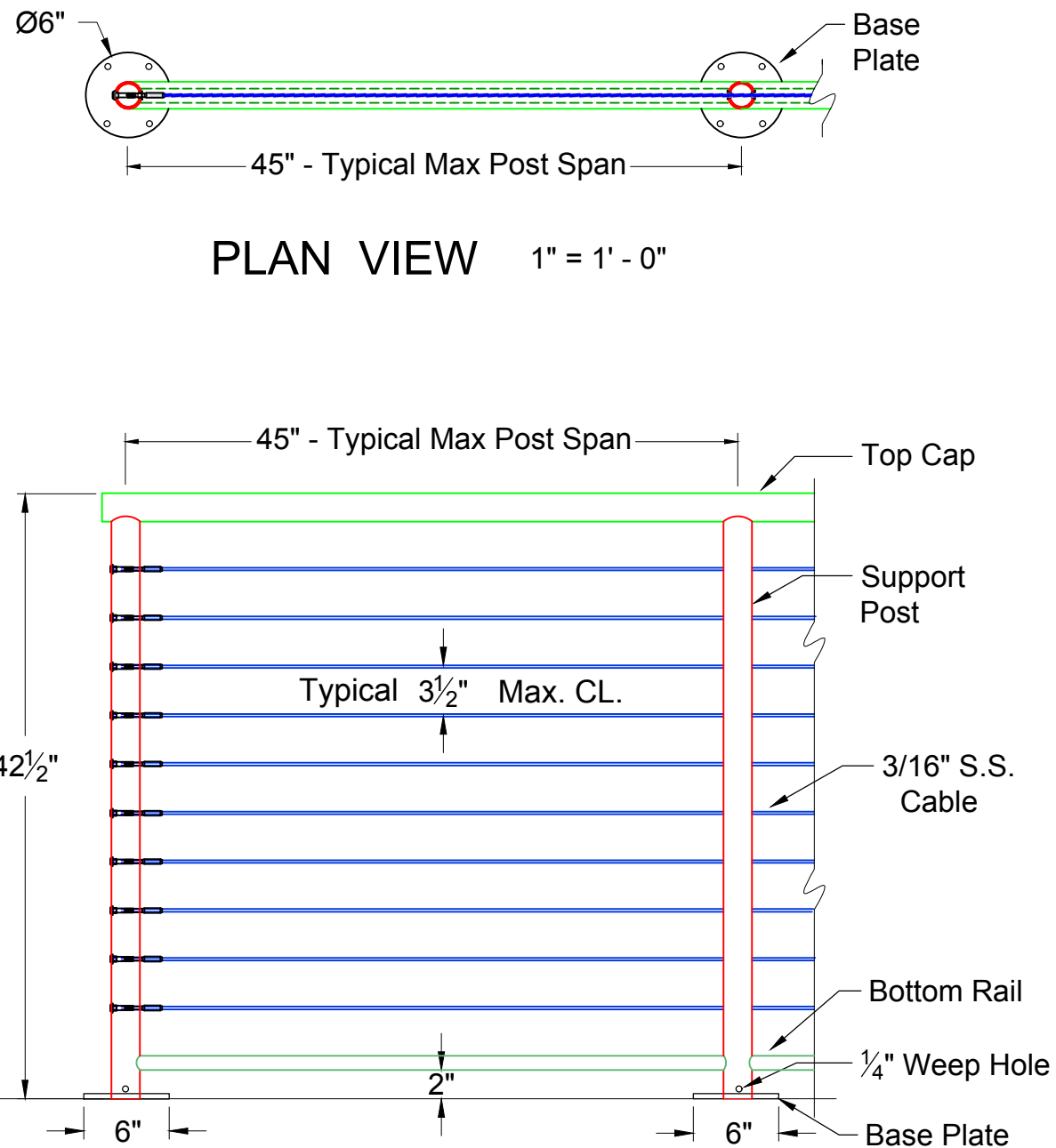

ELEVATION 1" = 1' - 0"

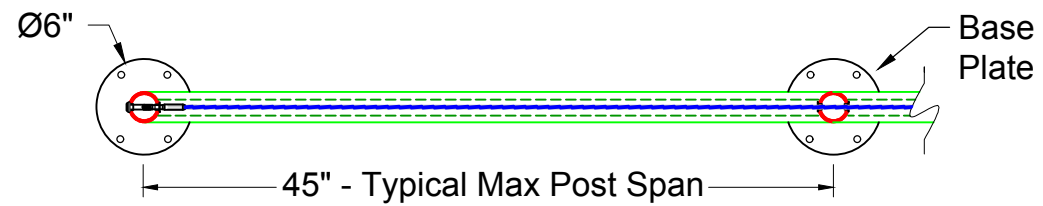

PLAN VIEW 1" = 1' - 0"

Dimensions and Components may vary based on Site Specific Engineering

Date:	May. 23, 19	Customer:	MULLET'S ALUMINUM
Drawn By:	Nick, L.	Project Name:	RAILINGS
Scale:	AS NOTED	Drawing Description:	CBRS - 200 S.S. Opt. Plate Mount
			Page : (2)

MULLET'S ALUMINUM PRODUCTS INC.
WELDING FABRICATION DEPT.
 6345 McIntosh Road Office # (941) 371 - 3502
 Sarasota, FL 34238 Fax # (941) 378 - 5676

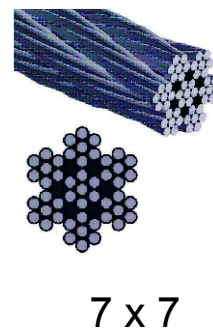
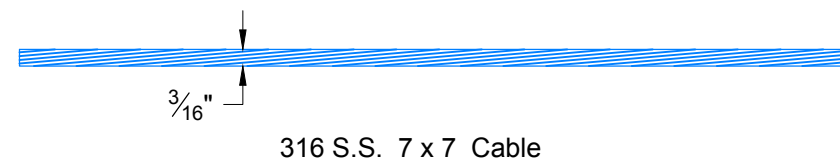
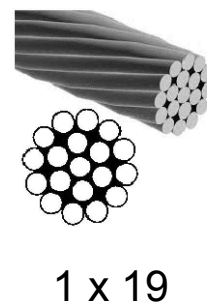
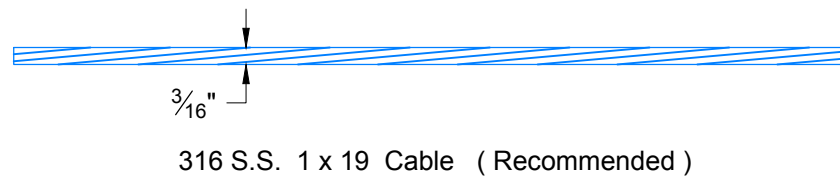
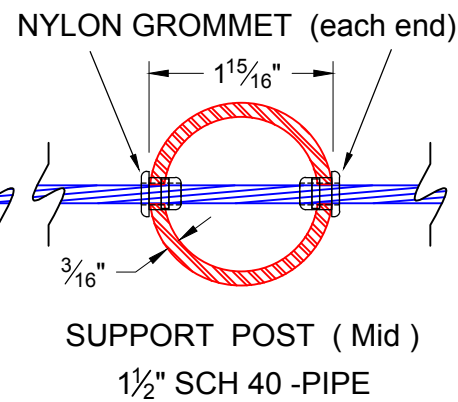
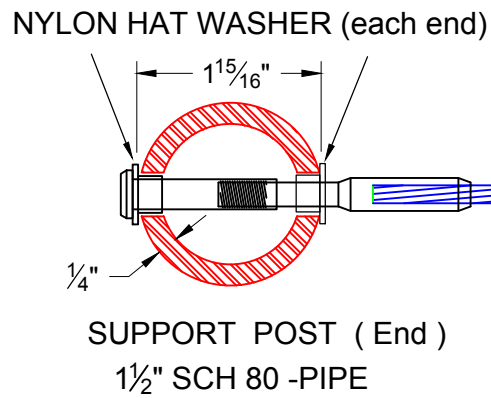
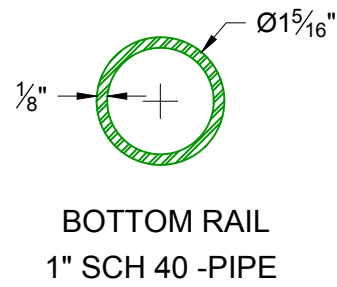
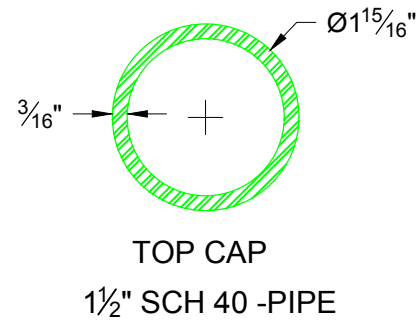

Material List: ALL 316 STAINLESS STEEL

1-15/16" x 3/16"	316 S.S. Sch 40-P	Top Cap
1-15/16" x 1/4"	316 S.S. Sch 80-P	Support Post (End)
1-15/16" x 3/16"	316 S.S. Sch 40-P	Support Post (Mid)
3/16" Dia.	316 S.S. 1 x 19	Cable (Recommended)
3/16" Dia.	316 S.S. 7 x 7	Cable (Option)
1-5/16 x 1/8"	316 S.S. Sch 40-P	Bottom Rail
6" Dia. x 3/8"	316 S.S. W.J. Cut	Base Plate (Option)

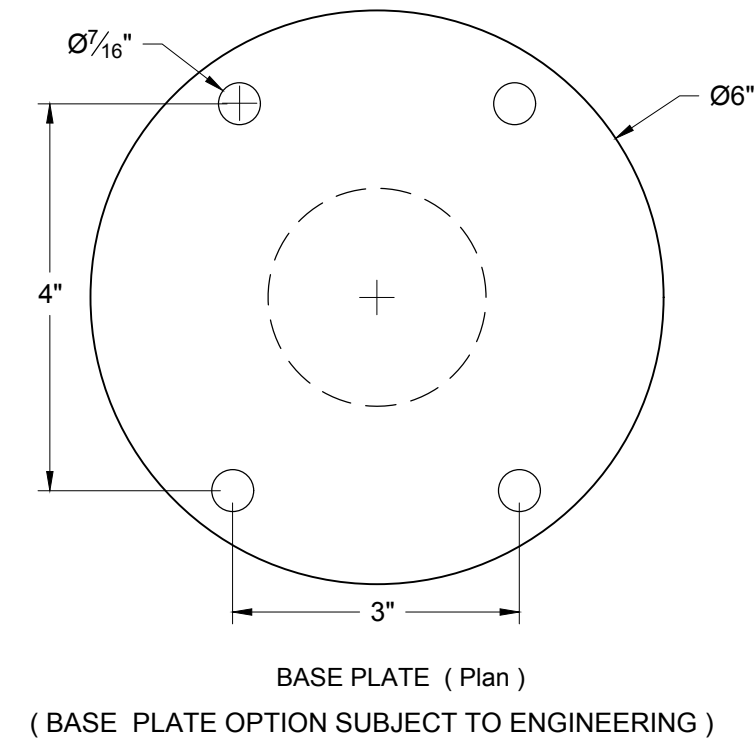
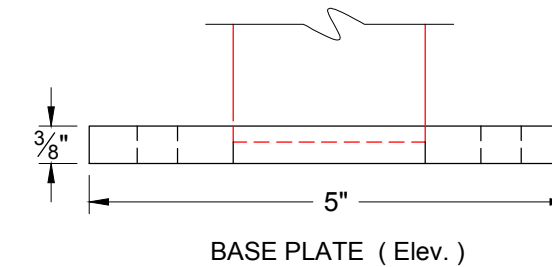

All rights reserved and are the property of Mullet's Aluminum Products, Inc. No part of the materials may be copied, photocopied, reproduced, translated or reduced to any electronic medium or machine-readable form, in whole or in part, without prior written consent of Mullet's Products, Inc. All materials are protected by United States Copyright Law.

Customer: **MULLET'S ALUMINUM**

Project Name: **RAILINGS**

Date: May. 23, 19
Drawn By: Nick, L.
Scale: N.T.S.
Drawing Description: **CBRS - 200 S.S. Component List**
Page: **(3)**



6345 McIntosh Road Office # (941) 371-3502
Sarasota, FL 34238 Fax # (941) 378-5676

Dimensions and Components may vary based on Site Specific Engineering